



RESEARCH PROTOCOLS

Terminating Cover Crops After Seeding Soybeans

Objective: Determine the agronomic and economic effects on soybean production of a cover crop that is terminated 2-4 weeks *after* seeding soybeans. **Hypothesis:** No reduction in soybean yield compared to when cover crop is terminated at planting, but improvements in weed control will result in better economic return.

Farmer-Cooperator will:

- Take photos throughout the project and keep in contact with PFI with updates and questions.
- **Fall 2018**, seed cereal rye cover crop at target population of 1 million PLS/ac.
- **Spring 2019**, establish at least 4 replications as shown in the diagram below.
 - **Terminate cover crop near the time of soybean seeding (0 DAP)**
 - **Terminate cover crop 2-4 weeks after time of soybean seeding (~20 DAP)**
- Strips will be as wide as at least one combine pass and run the length of the field.
- Collect aboveground biomass samples of cover crop from strips just prior to termination.
- Seed soybeans on same date for both treatments.
- **Summer 2019**, take photos of progress.
- Take soybean stand counts from each strip individually.
- **Fall 2019**, harvest soybeans from each strip individually.
- Turn in all info and data pertinent to this trial to Practical Farmers of Iowa by the end of the project

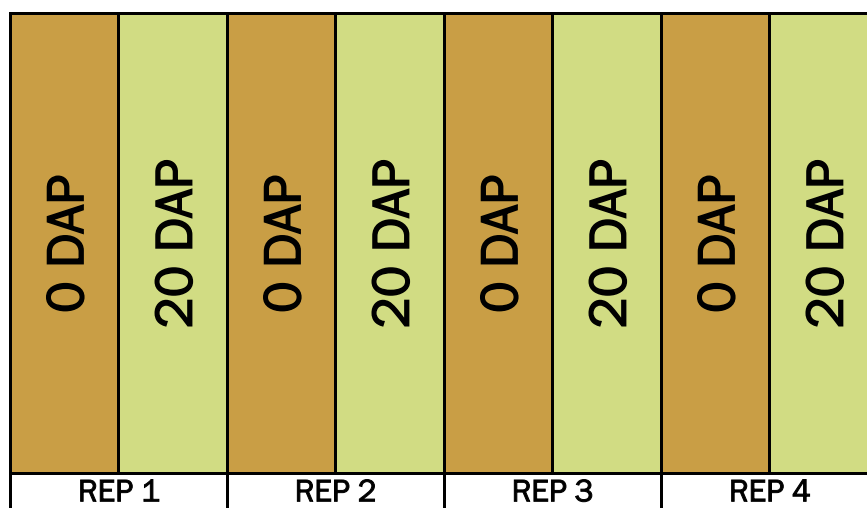

DAP = days after planting soybeans

Practical Farmers of Iowa will:

- Help set up monitoring protocol, monitor progress of project and provide support when needed.
- Publish results in a PFI research report, on PFI website and potentially other outlets.
- Provide \$550 honorarium when yield data is submitted at conclusion of the project in 2019.

Contact: Stefan Gailans, Research and Field Crops Director, (515) 232-5661; stefan@practicalfarmers.org

The terms of this Research Protocols document are subject to the terms of the individual Research Cooperator's Memorandum of Understanding agreement with PFI. To the extent these terms may differ or conflict, the Memorandum of Understanding shall control.